

# MTi-G

MINIATURE AHRS WITH INTEGRATED GPS



**xsens**

The MTi-G is a miniature size and low weight 6DOF Attitude and Heading Reference System (AHRS). The MTi-G contains accelerometers, gyroscopes, magnetometers in 3D, an integrated GPS receiver, a static pressure sensor and temperature sensor. Its internal low-power signal processor provides real time and drift-free 3D orientation as well as calibrated 3D acceleration, 3D rate of turn, 3D earth-magnetic field, 3D position and 3D velocity data.

The MTi-G is an excellent measurement unit for stabilization and control of air and ground objects, even during situations of long term accelerations.

#### Highlights

- Real-time computed GPS-enhanced attitude/heading and inertial enhanced position/velocity data
- GPS integration overcomes typical IMU challenges
- Integrated AHRS, GPS and static pressure sensor
- On board DSP, running sensor fusion algorithm
- High update rate (120 Hz), inertial data at max 512 Hz
- Individually calibrated for temperature, 3D misalignment and sensor cross-sensitivity
- UTC referenced output

#### Compact design

- Compact and robust design
- Easy integration in any system or application (OEM)
- Low weight, ultra-low power consumption

#### High performance

The MTi-G is a combination of a MEMS IMU, GPS and barometer. Yet, the MTi-G is more than just a sensor assembly. The IMU, GPS and barometric information is blended together in Xsens' sensor fusion algorithm to estimate the most accurate orientation and position possible. Because of this fusion, the output is more accurate than the output from the IMU or GPS receiver only. For example, the MTi-G copes with transient accelerations; a typical error source for any AHRS using the gravity as its reference estimating roll and pitch. The loose coupling works both sides: double-integrating the accelerometers for short periods, the MTi-G is able to calculate position and velocity even during short GPS outages. There are several more corrections realized to aid the IMU functionality and to enhance the GPS measurements.

#### User friendliness

The MTi-G is a sensor which can be used in a wide range of applications. Because of the specific requirements for all these applications, the MTi-G uses different filter settings and constraints, implemented in scenarios. Among others, there are scenarios for use in automotive and aerospace applications.

#### Output

- 3D orientation (360°)
- 3D position and velocity (aided and unaided by inertial sensors)
- 3D acceleration, 3D rate of turn
- 3D magnetic field



## TYPICAL USAGE APPLICATIONS



### Automotive

- Vehicle dynamics analysis
- Racing cars and motorbikes
- Performance testing

Full access to valuable data is available for engineers working in any level of sports car or motorbike competitions. The MTi-G outputs are suitable to test and analyze the dynamic behavior of e.g. automobiles. Non-holonomic constraints can be used to further enhance accuracy. The roll and pitch remains accurate even during long term accelerations typical for this application.



### Marine

- In-competition optimization of racing yachts
- State estimation of leisure yachts
- Backup system for high-grade GPS systems

For racing yachts, the MTi-G provides orientations of several parts of the ship, such as the roll angle of the hull or the movement of the mast. This allows a sailing team to refine the ship's performance during a race, or include the data in the autopilot. Another major application is commercial shipping. Measuring roll and pitch as well as heading is important for container ships, cargo ships and surveying vessels. Installing the MTi-G together with high grade GPS systems is a logical choice to enhance accuracy and to reduce costs, especially in situations with limited GPS reception.



### Unmanned ground vehicles and robotics

- Autonomous control for driving and walking robots
- Military and civil ground vehicles
- Camera/LIDAR stabilization and correction

The MTi-G is an excellent sensor for driving and walking robots. The main functionality of the MTi-G in robotics applications is attitude control, even under dynamic conditions. Accurate position and orientation makes autonomous navigation possible for Unmanned Ground Vehicles (UGV's), even on rough terrain or during short GPS outages. The MTi-G has been used in DARPA Grand Challenges for these purposes. These applications are typically out of reach for conventional MEMS IMU'S.



### Aerospace

- Autonomous attitude and navigation control
- Dynamics of (aerobatics) planes
- Camera/LIDAR stabilization and correction
- Head-up display

The MTi-G is the ideal choice for control and stabilization for any type of small to medium sized fixed-wing and rotary-wing aircraft. Because of the low latency, autonomous control can be designed in a simple and robust manner. The MTi-G provides a wide variety of dynamic data, suitable for dynamics analysis of (un)manned airplanes. An easy software/hardware interface makes data processing possible post-flight or even real-time. The MTi-G is easy to install and computes all the data required for e.g. an accurate artificial horizon or a digital map.

## MTi-G DEVELOPMENT KIT

### The MTi-G DK contains the following:

- MTi-G (any configuration)
- Antenna
- USB cabling
- MT Software Development Kit (see below)
- Hardcopy documentation
- Optional: serial cabling
- Suitcase

### MT Software Development Kit (MT SDK)

The MT SDK is an extensive set of tools for every level of interfacing, which allows configuring the MTi-G to the user needs, reading out and storing data and (re-)processing MTi-G data previously recorded. It also allows the user to extend own user source code with the MTi-G communication, using commands and code examples provided.

The MT SDK contains:

### MT Manager Software

A specially developed, easy-to-use graphical user interface with possibilities to configure Xsens' sensors, reading out, store and show data in real-time charts and visualizations.

### MT COM-object API and DLL API for Windows

Integrating the MTi-G in Windows programs, such as Matlab, C++ and Excel is made easy with the MT COM-object API and the DLL API. User-modifiable example code for programs Matlab, C++ and Excel (VBA) is included.

### C++ Class and binary communication for any (RT)OS

A C++ class is available for users who want to use the MTi-G on a binary level. Direct communication without using the C++ class is possible, following the fully documented communication protocol.

### Magnetic Field Mapper plug-in

The Magnetic Field Mapper plug-in enables compensation for hard and soft iron effects.



## ACCESSORIES

### Cable options CA-USB2G



USB cable

### CA-SERi-2,5



Serial cable  
RS232 + pigtail

### CA-DB9iG



RS232, DB9  
power

### PA-MP



Power adapter  
(for CA-DB9iG only)

### ANT



Antenna



**XSENS**

## MTi-G TECHNICAL SPECIFICATIONS

### Attitude and heading

Static accuracy (roll/pitch)	<0.5 deg
Static accuracy (heading) <sup>1</sup>	<1 deg
Dynamic accuracy <sup>2</sup>	1 deg RMS
Angular resolution <sup>3</sup>	0.05 deg
Dynamic range:	
- Pitch	± 90 deg
- Roll/Heading	± 180 deg
Maximum update rate:	
- Onboard processing	120 Hz
- External processing	512 Hz

### Position

Accuracy position:	
- SPS	2.5 m CEP
Maximum update rate:	
- Onboard processing	120 Hz
- External processing	512 Hz

### Interfacing

Digital interface	RS-232(max 921k6 bps) and USB (ext. converter)
Operating voltage	5 - 30V
Power consumption	610-690 mW (typical) - 910 mW (max)
Interface options I/O	SyncOut, AnalogIn (2x),
GPS antenna	SMA connector, active

### Maximum operational limits

Altitude	18 km
Velocity	515m/s (1854 km/h)
Ambient temperature operating range <sup>4</sup>	-20...+55 °C
Specified performance operating range <sup>4</sup>	0.. +55 °C

## INDIVIDUAL SENSOR SPECIFICATIONS

### Sensor performance

Dimensions	3 axes
Full Scale (standard)	± 300 deg/s
Linearity	0.1% of FS
Bias stability <sup>4</sup>	1 deg/s
Scale Factor stability <sup>5</sup>	-
Noise	0.05 deg/s/√Hz
Alignment error	0.1 deg
Bandwidth	40 Hz
Max update rate	512 Hz

### Rate of turn

3 axes
± 300 deg/s
0.1% of FS
1 deg/s
-
0.05 deg/s/√Hz
0.1 deg
40 Hz
512 Hz

### Acceleration

3 axes
± 50 m/s <sup>2</sup>
0.2% of FS
0.02 m/s <sup>2</sup>
0.03%
0.002 m/s <sup>2</sup> /√Hz
0.1 deg
30 Hz
512 Hz

### Magnetic field

3 axes
± 750 mGauss
0.2% of FS
0.1 mGauss
0.5%
1.5 mGauss
0.1 deg
10 Hz
512 Hz

### Static pressure

-
30-120 kPa
0.5% of FS
100 Pa/yr
-
4 Pa/√Hz (0.3 m/√Hz)
-
9 Hz

### GPS

Receiver type	50 channels L1 frequency, C/A code Galileo L1 Open Service
GPS update rate	4 Hz
Start-up time cold start	29 s
Tracking sensitivity	-160 dBm
Timing accuracy	50 ns RMS

## HARDWARE SPECIFICATIONS

### Housing

Dimensions (WxLxH)	58x58x33 mm
Weight	68 g

### Options

Full scale acceleration:	Full scale rate of turn:
5g (50 m/s <sup>2</sup> )	150 deg/s G15
18g (180 m/s <sup>2</sup> )	300 deg/s G35
	1200 deg/s G25

Product code:	MTi-G-28 A## G##
Standard version:	MTi-G-28 A53 G35

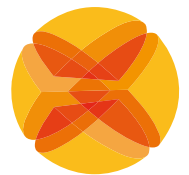
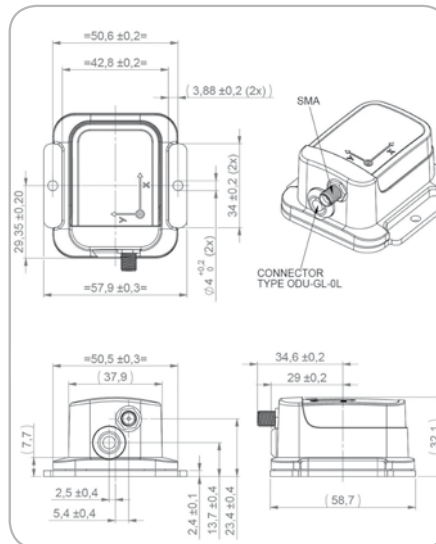

**XSENS**

Note: Specifications subject to change without notice

<sup>1</sup> depends on usage scenario. In case the Earth magnetic field is used, it must be homogeneous  
<sup>2</sup> under condition of a stabilized Xsens sensor fusion algorithm and good GPS availability  
<sup>3</sup> standard deviation of zero-mean angular random walk  
<sup>4</sup> non-condensing environment  
<sup>5</sup> deviation over operating temperature range

## ABOUT XSSENS TECHNOLOGIES

Xsens is a leading supplier of 3D motion tracking products based upon miniature MEMS inertial sensor technology. Since its inception in 2000, several thousands of motion sensors and motion capture solutions have successfully been deployed in areas such as 3D character animation, rehabilitation and sports science, and robot and camera stabilization. Customers include Electronic Arts, Sony Pictures Imageworks, INAIL Prosthesis Centre, Daimler, Saab Underwater Systems, Kongsberg Defence & Aerospace and many other companies and institutes throughout the world.

Xsens' research department has created unique intellectual property in the field of multi-sensor data fusion algorithms, combining inertial sensors with aiding technologies such as GPS and RF positioning and biomechanical modeling. The company and its products have received several awards, amongst which four consecutive entries in Deloitte's ranking of fastest growing technology companies in Europe.

Xsens is headquartered in Enschede, The Netherlands and has a subsidiary in Los Angeles, California, US.



**xsens**

### **Xsens Technologies B.V.**

phone +31 88 97367 00

fax +31 88 97367 01

e-mail [info@xsens.com](mailto:info@xsens.com)

internet [www.xsens.com](http://www.xsens.com)